

BINKS[®]

Instruction Manual

For

Maple 7-15 Pump

Model 104041

Note: Read and follow all instructions and safety precautions before using this equipment

Product Description

104041 – Maple 7-15 Pneumatic Pump



This equipment is designed for use with Solvent based and Waterborne materials.
Suitable for use in Zone 1 and 2, Protection Level: **II 2 G X**

Manufacturer: - Binks PCE
Justus-von-Liebig-Straße 31,
63128 Dietzenbach. DE

EU Declaration of Conformity

We: Binks declare that the above product conforms with the Provisions of Machinery Directive 2006/42/EC and the ATEX Directive 94/9/EC by complying with the following statutory documents and harmonized standards: -

Machinery Safety Standards EN ISO 12100, EN ISO 4413, EN ISO 4414 & EN12621
Explosion Prevention Potentially Explosive Atmospheres EN 1127-1
Non-electrical Equipment for Potentially Explosive Atmospheres BS EN 13463-1
Constructional Safety for Potentially Explosive Atmospheres EN 13463-5

Providing all conditions of safe use stated within the product manuals have been complied with and that the final equipment into which this product is installed has been re-assessed as required, in accordance with essential health and safety requirements of the above standards, directives and statutory instruments and also installed in accordance with any applicable local codes of practice.

A handwritten signature in black ink, appearing to read 'H. Beiersdorfer'.

H Beiersdorfer (General Manager)
24th May 2012

Index

Section

- 1.1 General Description
- 1.2 Operating Principle
- 1.3 Specifications
- 1.4 Dimensions and Mounting Details

- 2.1 Important Safety Information

- 3.1 Installation - General

- 4.1 Parts Lists Main Pump
- 4.2 Parts Lists Air Motor
- 4.3 Parts Lists Fluid Section
- 4.4 Parts Lists Reference

- 5.1 Maintenance – Air Motor Assembly Procedure
- 5.2 Maintenance – Fluid Section Assembly
- 5.3 Maintenance – Final Pump Assembly
- 5.4 Maintenance – Disassembly Procedure

- 6.1 Maintenance - General
- 6.2 Maintenance - Fault Finding

- 7.1 Spare Parts Lists
- 7.2 Accessories

General Description – Section 1.1

High Quality materials and surface treatments are used in the construction of this pump to ensure both extended operational life and good future appearance.

The Maple pump is a horizontal piston pump for pumping Solvent / Waterborne Paints, Solvents and other suitable materials.

An Ø180 x 50mm stroke air motor is used to drive two fluid sections giving a combined output of 0.166 L per cycle.

The unit combines an energy efficient air motor with low shear fluid section technology from the range of Smart Electric Pumps.

The Maple Pump achieves a reciprocating drive by using high technology ground and lapped steel spool and sleeve air valves to control the air motor reversal, providing reciprocating motion.

The air valve design (patent pending) ensures a positive magnetic detent for the main and pilot air valves thus removing the possibility for a stall condition.

The air motor also utilises the Binks Low Ice quick exhaust technology to prevent air valve freezing conditions when high cycle speeds are employed.

Equal thrust on each stroke due to the horizontal configuration incorporating the dual piston rod design gives a balanced fluid pressure output and reduces fluid pressure fluctuations to a minimum.

The air pump is furnished with twin exhaust mufflers to control exhaust noise emission. An adapter kit is available to facilitate connection to a piped exhaust system if required.

A 1/8" Port is incorporated into the main air valve to facilitate an optional cycle counter.

Complies with current relevant European and US Legislation

Operating Principle – Section 1.2

The Assembly comprises of:-

- Central Air Piston and 'change over' Valves
- 2 off Quick Exhaust and muffler assembly
- 2 off Dynamic Chambers and Fluid Pistons
- 2 off Fluid Pressure Chambers each complete with Suction and Pressure Ball Check Valve Assemblies
- 1 off Fluid Inlet Manifold
- 1 off Fluid Outlet Manifold
- Support Bracket

The Pumps have horizontally opposed positive displacement pistons connected to a common reciprocating air motor piston. The pneumatically driven piston actuates pilot air control valves at the end of its travel producing an air logic signal to shuttle the spool valve initiating the opposite stroke.

The air pilot valves contain no springs. They are operated by magnetic force and reset by the main piston air supply and retained in position by a magnetic detent. The main spool valve is air piloted and contains two exhaust ports. Both the pilot valves and the main spool valve are easily removable.

There are no external air pilot hoses. The air logic and exhaust ports are internal. Simply mounting the spool valve and the pilot valves assures that the logic circuits are connected properly.

The air cylinder exhaust air is channelled through two independent quick exhaust valves to minimise piston reversal time.

The "4-Ball" fluid section design refers to the two sets of ball checks. Each fluid chamber has an inlet and outlet ball check, the inlet check is uniquely positioned in the piston saving space and reducing the overall weight of the pump. The inlet and outlet ball checks are connected by a common inlet manifold and outlet manifold respectively.

A bellows provides the fluid seal on the connecting rod within the inlet chamber, whilst a main piston seal maintains the pump fluid pressure within the pressure chamber. When the main piston seal starts to pass fluid due to wear, any leakage passes into the inlet chamber.

Specification – Section 1.3

Specification	
Pump Ratio	15:1
Max. Air Pressure Inlet	7 Bar
Max. Fluid Pressure	105 Bar
Nominal Flow Volume / Cycle	0.166 Litres 0.044 US Gall
Fluid Output @ 60 cycles/min	10.0 Litres / min 2.6 US Gall / min
Maximum Recommended Continuous Cycle Rate Maximum Recommended Intermittent Cycle Rate	20 Cycles /min 40 Cycles /min
Fluid Connections Inlet Outlet	1" Sanitary ½" NPT Female
Air Volume / cycle	0.33 SCFM (9.5 L/m) @ 45PSI (3.1 Bar) 0.65 SCFM (18.5 L/m) @ 90 PSI (6.2 Bar)
Air Flow @ 15 cycles/min 6 bar Air Flow @ 30 cycles/min 6 bar	10 CFM (283 L/min) 20 CFM (566 L/min)
Air Quality ISO 8573.1 Class 3.3.2 # (See Note)	Dirt 5 microns Water -20°C@7bar (940ppm) Oil 0.1mg/m ³
Total Weight of Pump	30 Kg / 66 lbs
<p># Note: Class 3.4.2 Air Quality (Refrigerant dried - water +3°C@7bar) may be used, however, above 15 cycles/min optional heavy duty mufflers 192821 or piped exhaust system should be used.</p>	

Dimensions and Mounting Details – Section 1.4

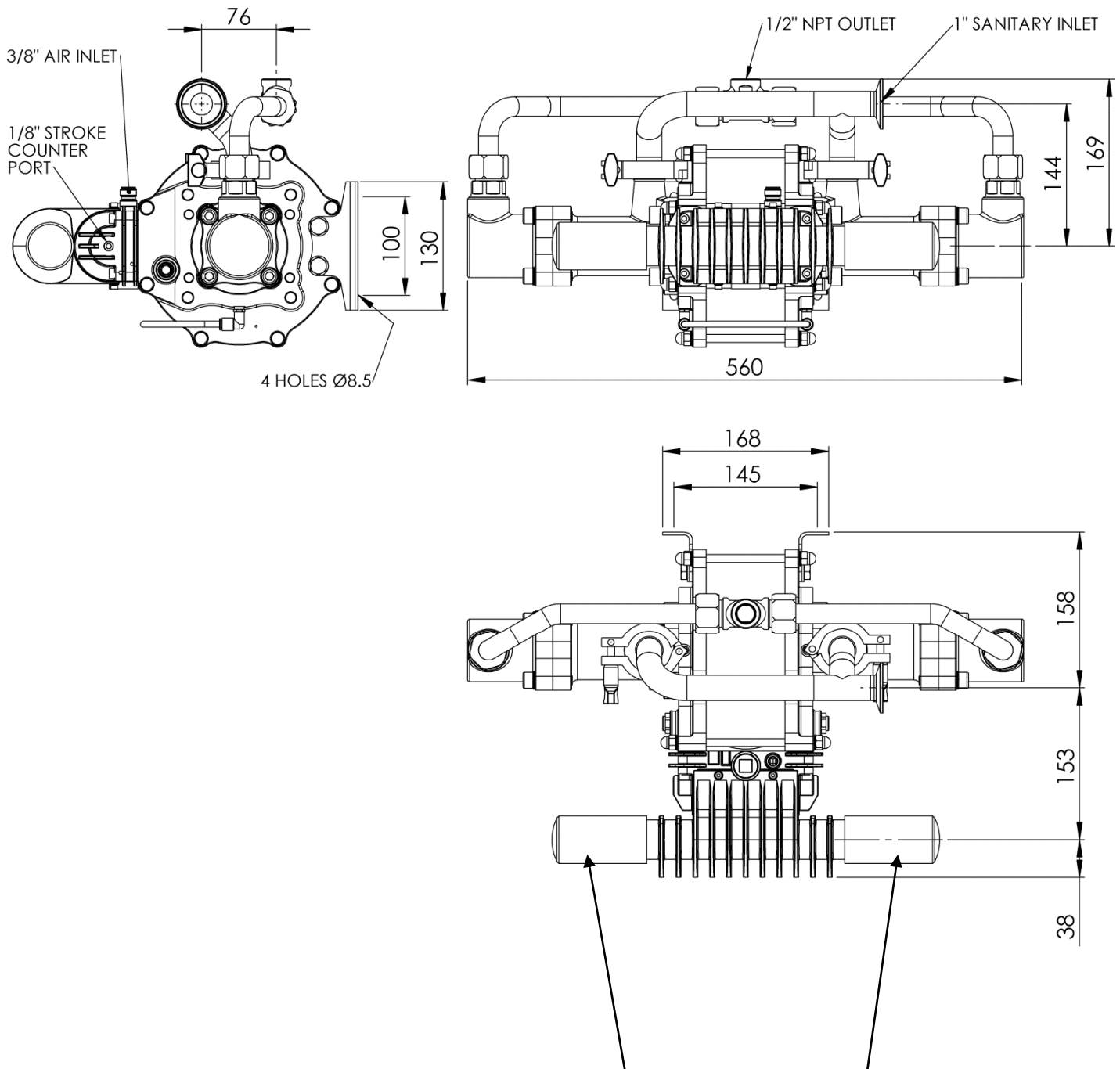

For Piped Exhaust Air, remove mufflers and add 192803 Plug and Hose Adapter 192779 for 1" NB Hose or 192820 for 1 1/4" NB Hose.

Important Safety Information - Section 2.1

Directions for Working Safety

This Product has been constructed according to advanced technological standards and is operationally reliable. Damage may, however, result if it is used incorrectly by untrained persons or used for purposes other than those for which it was constructed.

The locally current regulations for safety and prevention of accidents are valid for the operation of this product under all circumstances.

International, national and company safety regulations are to be observed for the installation and operation of this product, as well as the procedures involved in maintenance, repairs and cleaning.

These instructions are intended to be read, understood and observed in all points by those responsible for this product. These operating and maintenance instructions are intended to ensure trouble free operation. Therefore, it is recommended to read these instructions carefully before start-up. Binks PCE cannot be held responsible for damage or malfunctions resulting from the non-observance of the operating instructions. These instructions including regulations and technical drawings may not be copied, distributed, used for commercial purposes or given to others either in full or in part without the consent of Binks PCE. We reserve the right to alter drawings and specifications necessary for the technical improvement of this product without notice.

High Pressure/Electrostatic Warning

High pressure equipment can be dangerous if used incorrectly, serious bodily injury may occur if the following instructions are ignored. Installation and maintenance should only be carried out by suitably qualified personnel.

1. Before attempting any work on a high-pressure system ensure material pump, hydraulics, compressed air motor are isolated where relevant.
 2. Relieve all pressure from the system. Note: It is possible for pressure to get locked into a system, therefore, ensure all sections of the system are checked thoroughly for remaining pressure.
 3. Take care when releasing fittings
 4. Always replace worn hoses immediately
 5. Never plug a leak with your finger, adhesive tape or other stop gap devices
- Always ensure equipment is suitably earthed before running, to avoid any chance of electrostatic build up.

Equipment Misuse Hazard

Equipment misuse can cause the equipment to rupture or malfunction and result in serious injury.

- This equipment is for professional use only.
- Read all instruction manuals, tags, and labels before operating the equipment.
- Use the equipment only for its intended purpose.
- Do not alter or modify this equipment. Use only genuine ITW parts and accessories.
- Check equipment daily. Repair or replace worn or damaged parts immediately.
- Do not exceed the maximum working pressure stated on the equipment or in the Technical Data for your equipment. Do not exceed the maximum working pressure of the lowest rated component in your system.
- Use fluids and solvents which are compatible with the equipment wetted parts. Refer to the Technical Data section of all equipment manuals. Read the fluid and solvent manufacturer's warnings.
- Route hoses away from traffic areas, sharp edges, moving parts, and hot surfaces. Do not expose hoses to temperatures above 82°C (180°F) or below -40°C (-40°F).
- Wear hearing protection when operating this equipment.
- Do not lift pressurized equipment.
- Comply with all applicable local, state, and national fire, electrical, and safety regulations.

Important Safety Information - Section 2.1

Fire, Explosion and Electric Shock Hazard

Improper grounding, poor ventilation, open flames or sparks can cause a hazardous condition and result in a fire, explosion, or electric shock.

When installed and operated in accordance with its instructions, the pump is approved for operation in Zone 1 (Europe) & Division 1 (North America), hazardous locations. (ATEX Cat 2)

- Electrical equipment must be installed, operated, and serviced only by trained, qualified personnel who fully understand the requirements stated in this instruction manual.
- Ground the equipment and all other electrically conductive objects in the spray area. After grounding test with ohmmeter to ensure earth continuity is 1 ohm or less.
- Keep all covers tight while the motor is energized.
- If there is any static sparking or you feel an electric shock while using this equipment, stop spraying/dispensing immediately. Do not use the equipment until you identify and correct the problem.
- Provide fresh air ventilation to avoid the build up of flammable fumes from solvents or the fluid being pumped.
- Keep the pumping area free of debris, including solvent, rags, and gasoline.
- Electrically disconnect all equipment in the pumping area.
- Extinguish all open flames or pilot lights in the spray/dispense area.
- Do not smoke in the spray/dispense area.
- Do not turn on or off any light switch in the spray/dispense area while operating or if fumes are present.
- Do not operate a gasoline engine in the spray/dispense area.

Hot Surface Hazard

- The electric motor becomes hot during operation, and the heat may be transferred to other connected equipment. To reduce the risk of burning yourself, do not touch the motor surfaces while it is operating. Before servicing, allow the motor to cool.
- Keep flammable materials and debris away from the equipment.

Pressurized Equipment Hazard

Spray from the gun/valve, hose leaks, or ruptured components can splash fluid in the eyes or on the skin and cause serious injury.

- Do not point the gun/valve at anyone or at any part of the body.
- Do not stop or deflect leaks with your hand, body, glove or rag.
- Spraying/dispensing; clean, check, or service the equipment.
- Tighten all fluid connections before operating the equipment.
- Check the hoses, tubes, and couplings daily. Replace worn, damaged, or loose parts immediately. Permanently coupled hoses cannot be repaired; replace the entire hose.

Toxic Fluid Hazard

Hazardous fluid or toxic fumes can cause serious injury or death if splashed in the eyes or on the skin, inhaled, or swallowed.

- Know the specific hazards of the fluid you are using.
- Store hazardous fluid in an approved container. Dispose of hazardous fluid according to all local, state and national guidelines.
- Always wear protective eyewear, gloves, clothing and respirator as recommended by the fluid and solvent manufacturer.

Moving Parts Hazard

- Keep clear of all moving parts when starting or operating the pump.

Installation – Section 3.1

Mount the pump securely and position the pump at a convenient height (below the lid height of the paint container), to allow for maintenance, visual observation, and periodic inspection.

The wall mount bracket is included with all pumps.

Exhaust silencer kits are available for these pumps if the air exhaust is required to be piped away from the pump rather than exhausting locally through the mufflers.

The Pump Mounting Frame must be connected to a suitable earth ground to ensure that there is no possibility of static build up.

Attach suitable flexible hoses to the inlet and outlet connections

Connect a suitable 3/8 NB air hose and 1/2" Pressure Filter Regulator to the air motor. (Filter rated at minimum 1000 L/min)

No additional air lubrication is required as piston 'O'-ring lubricant is applied during assembly or repair. If an air lubricator is used to prolong piston seal life (for example continuous duty at high pump cycle rates) then this must be maintained as the lubricant removes the piston seal assembly grease.

Set the pump speed to a slow cycle rate and start the pump to remove any air from the fluid circuit. Inspect for any air or fluid leaks.

If an air blow out system is used, never exceed 2 Bar feeding the inlet of the pump.

Parts List – Section 4.1

Parts List – 104041 Main Pump Assembly				
ITEM	PART No	DESCRIPTION	QTY	REMARKS
1	-----	AIR MOTOR ASSEMBLY	1	
2	-----	FLUID SECTION ASSEMBLY	2	
90	192777	MUFFLER	2	
91	192009	SANITARY CLAMP	4	
92	192206	SANITARY GASKET	4	1 2
93	193360	INLET MANIFOLD	1	
94	193419	OUTLET MANIFOLD ASSEMBLY	1	

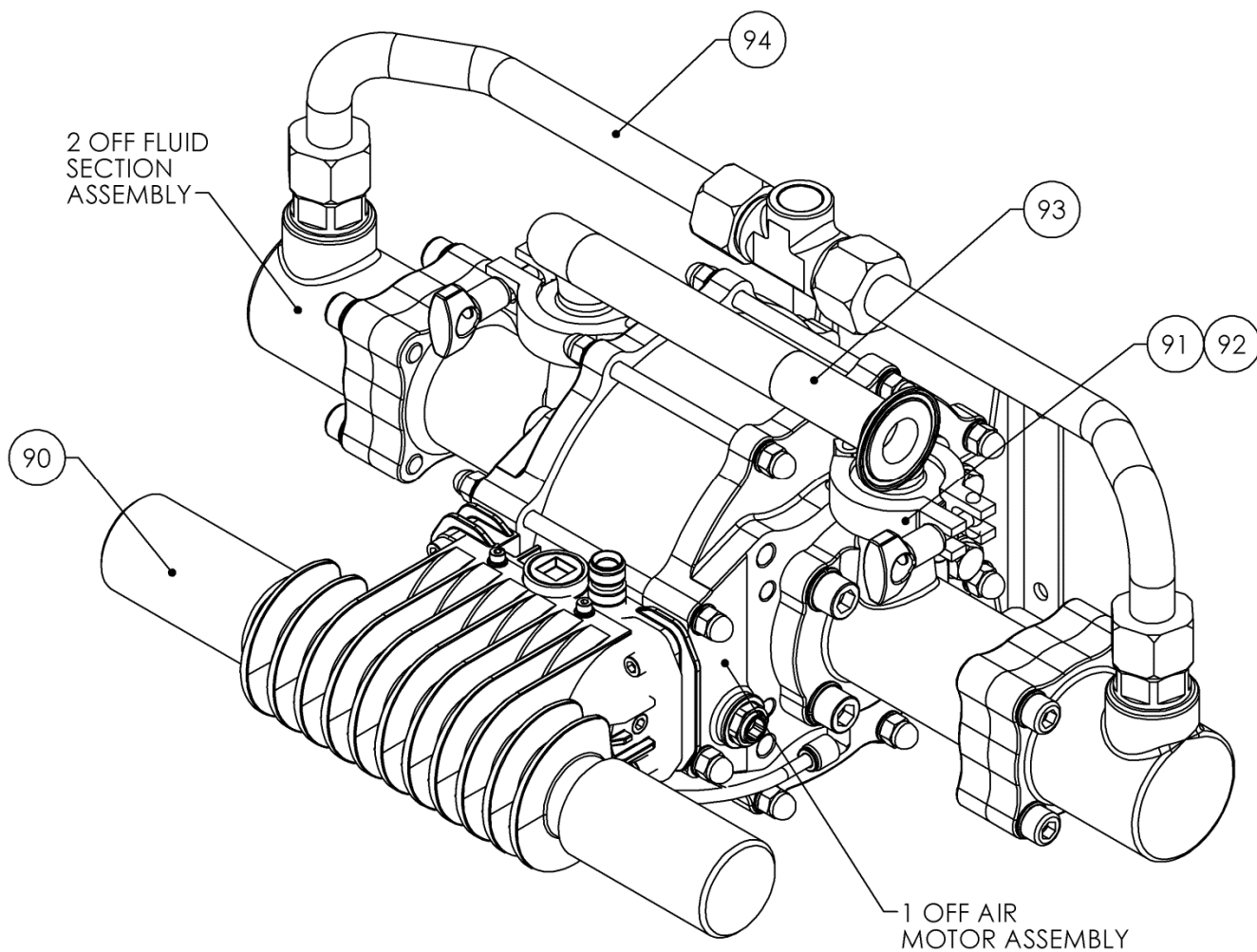

Parts List – Section 4.2

Parts List - Air Motor Assembly				
ITEM	PART No	DESCRIPTION	QTY	REMARKS
3	0115-010102	MAIN AIR VALVE ASSEMBLY	1	
4	161992	Ø177.5 x 2.62 VITON O-RING	2	③
5	161993	Ø20.35 x 1.78 VITON O-RING	2	③
6	161994	Ø4.47 x 1.78 O-RING	4	③
7	161995	Ø19.5 x 3.00 O-RING	2	③
8	162702	PISTON SEAL	1	③
9	162703	SHAFT SEAL	2	③
10	162704	SHAFT BEARING	2	③
11	163920	M6 x 30 CAP HD SCREW	4	
12	165108	M8 SPRING WASHER	16	
13	165135	M10 PLAIN WASHER	4	
14	165528	M4 x 16 CAPHEAD SET SCREW	4	
15	165963	M8 HEX NUT	16	
16	165964	M12 x 40 GRUBSCREW	1	
17	165965	M10 x 16 HEX HEAD SET SCREW	4	
18	165970	M4 PLAIN WASHER	4	
19	165971	Ø4 SPRING WASHER	4	
20	192374	RETAINING NUT	2	
21	192579	KNIFED BELLOWS	2	②
22				
23	192757	CYLINDER	1	
24	192758	END PLATE	2	
25	192759	PISTON SHAFT	2	
26	192760	PISTON	1	
27	192761	CYLINDER STUD	6	
28	192762	CYLINDER STUD (LONG)	2	
29	192763	BELLOWS SPACER	2	
30	192764	PUMP BRACKET	2	
31	192765	PILOT VALVE ASSEMBLY	2	#
32	192799	VENT PLUG	2	
33	192812	EXHAUST ADAPTER	1	
34	192814	BELLOWS LEAK DETECTION HOSE	1	②
35	192815	1/8R - 6MM PUSH IN ELBOW	2	②

Parts List – Section 4.2

Air Motor Assembly

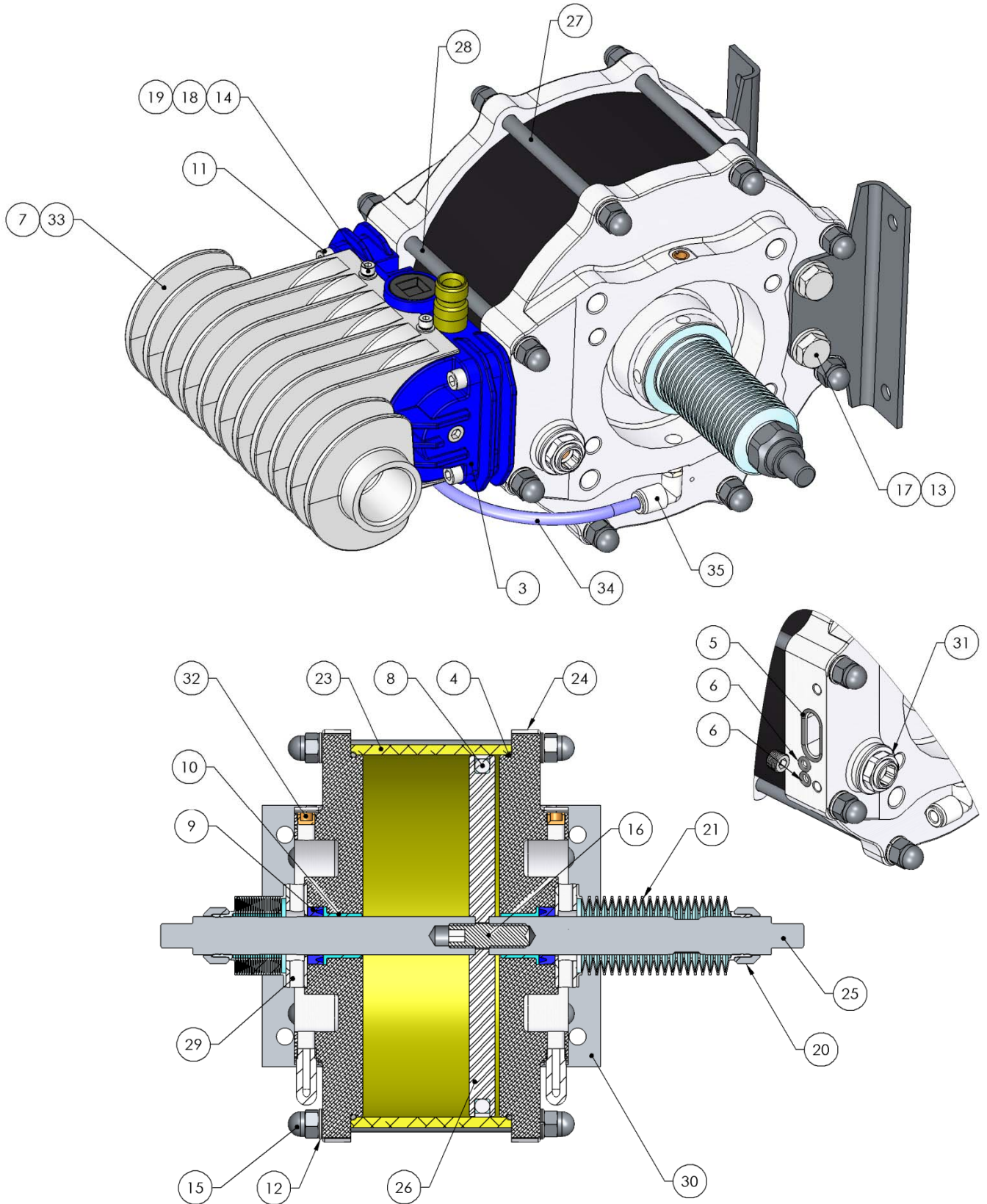

Parts List – Section 4.2

Parts List - 0115-010102 Main Air Valve Assembly				
ITEM	PART No	DESCRIPTION	QTY	REMARKS
40	0115-010097	VALVE BLOCK ASSEMBLY	1	
41	0115-010015	MAIN SPOOL & SLEEVE VALVE ASSY	1	#
42	0115-010016	BUMPER	2	③
43	0115-010017	MAGNET	2	
44	0115-010018	END CAP	2	
45	192813	QE VALVE CAGE	2	
46	0115-010020	QEV DIAPHRAGM	2	③
47	0115-010021	Ø36 x 1.5 O-RING	2	③
48	0115-010049	Ø20 x 2 O-RING	2	③
49	0115-010073	M4 x 12 BUTTON HD CAP SCREW	8	
50	0115-010107	1/8" PLUG	1	
51	0114-014657	1/4 " PLUG	1	
52	180584	AIR INLET FITTING (3/8")	1	
	162789	SPOOL & SLEEVE 'O' RING	6	③ - Not Shown

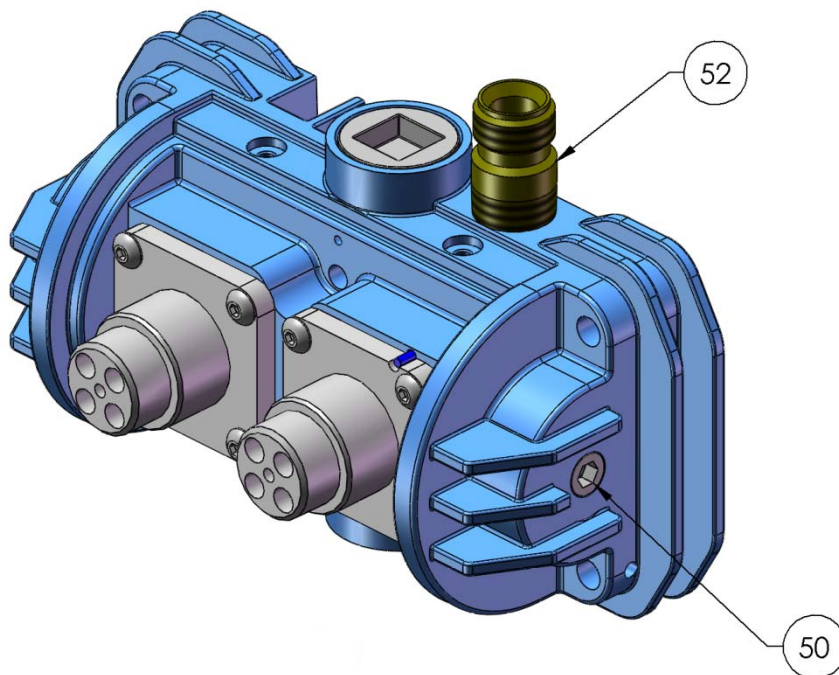

Parts List – Section 4.2

0115-010102 Main Air Valve Assembly

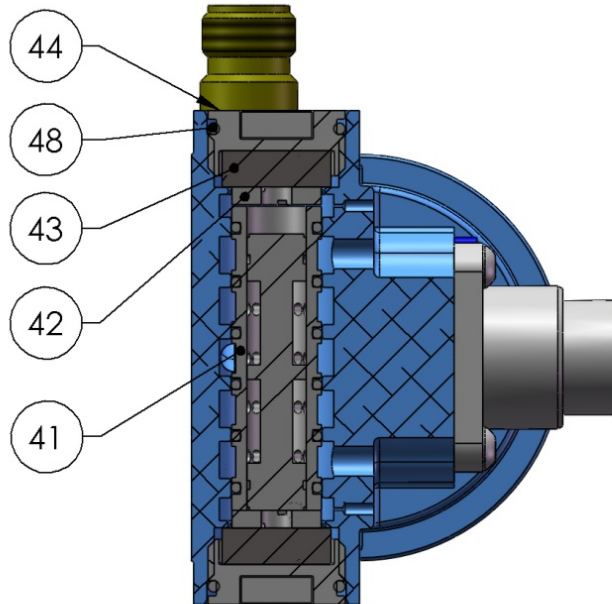

SPOOL DETAIL

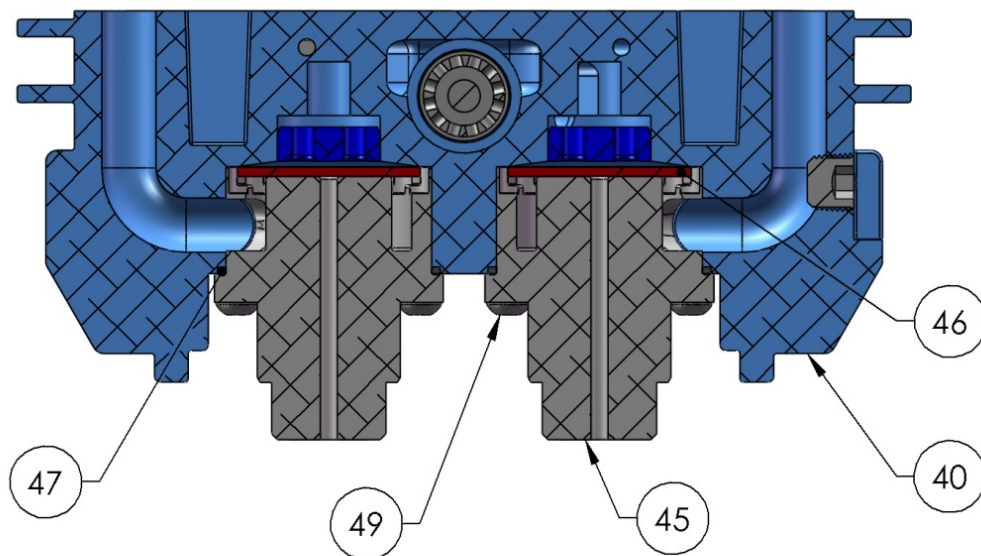

QUICK EXHAUST DETAIL

Parts List – Section 4.3

Parts List – Fluid Section				
ITEM	PART No	DESCRIPTION	QTY	REMARKS
60	160526	CONICAL SPRING	1	① ②
61	162743	Ø31.42 X 2.62 O RING PTFE	1	① ②
62	162744	Ø23.52 X 1.78 ORING PTFE	1	① ②
63	162745	Ø29.9 X 1.78 O'RING PTFE	1	① ②
64	162746	Ø25 X 1.6 O'RING PTFE	1	① ②
65	165044	M12 SPRING WASHER	4	
66	165123	M10 SPRING WASHER	4	
67	165948	M10 x 40 CAP HD SCREW	4	
68	171714	3/4 BALL 440C	1	②
69	177009	M12 x 35 CAP HD SCREW	4	
70	193181	7/8" BALL	1	②
71	193188	INLET SPRING KEEP	1	① ②
72	193189	PISTON SEAT	1	②
73	193190	OUTLET SEAT	1	②
74	193225	OUTLET CYLINDER	1	
75	193358	Ø46 PISTON	1	
76	193359	PISTON KEEP	1	
77	193361	INLET CYLINDER	1	
78	193367	OUTLET CHECK	1	
79	193195	PISTON SEAL	1	# ① ②
80				
81				
82				
83				
84				

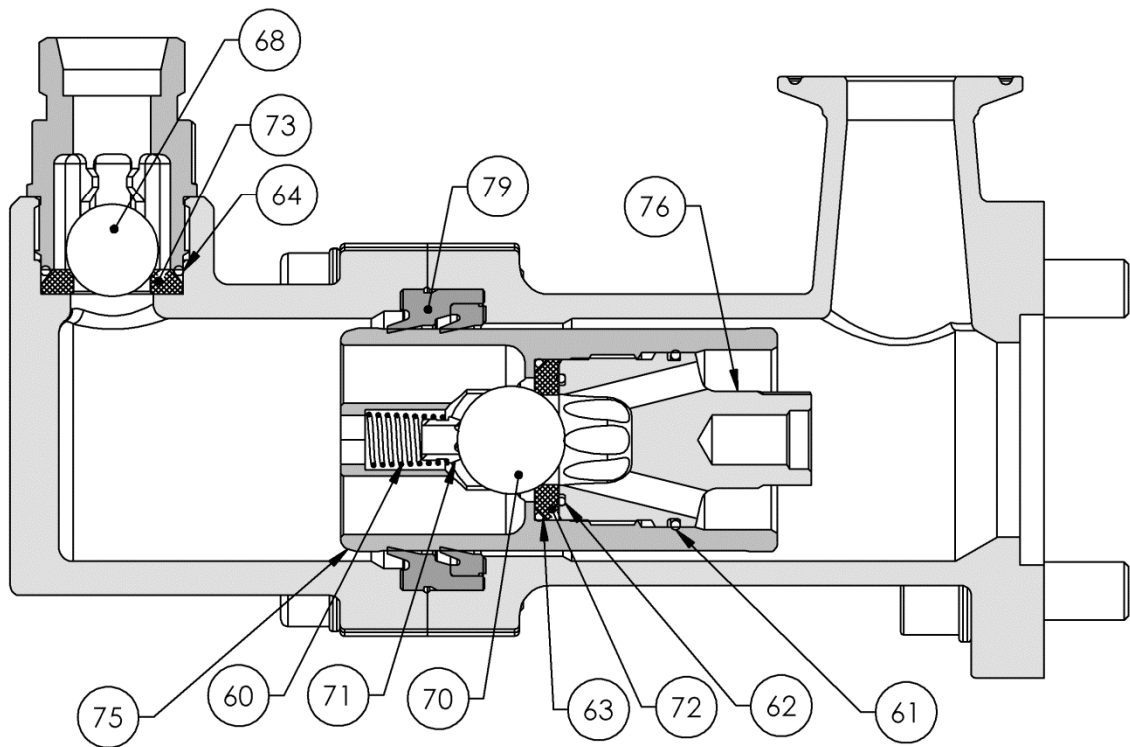
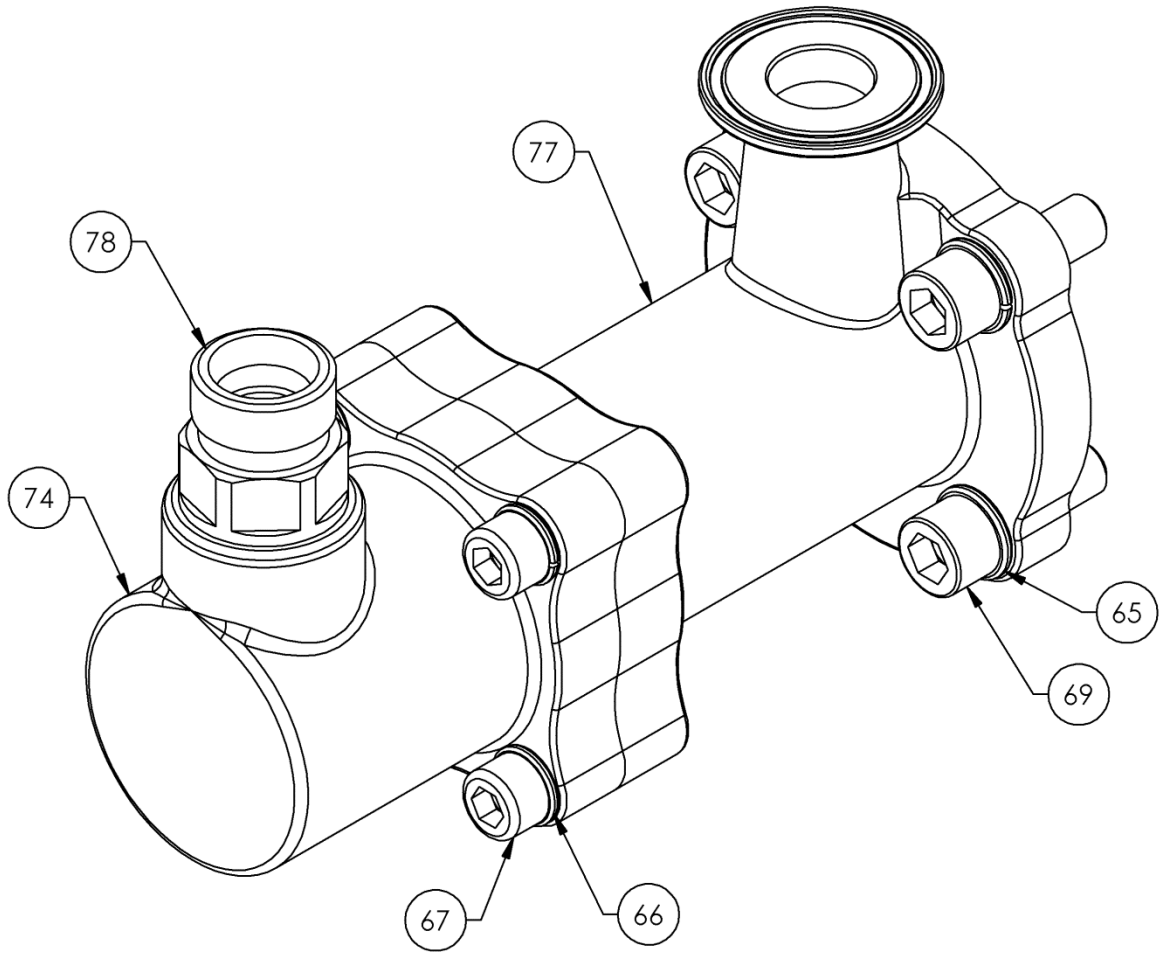

Parts List – Section 4.4

For Reference Only

The Pilot Spool (31) is available as a completed and tested assembly; the drawing below is for reference and identification only.

If the pilot spool is removed from the air motor for inspection it is recommended that the 3 off O-ring seals (H) are replaced and lightly greased. Spare Pilot Valves are fitted with the 3 off O-ring 192773.

ITEM	PART No	DESCRIPTION	QTY	REMARKS
H	192773	Ø17 O-RING	3	Ⓢ

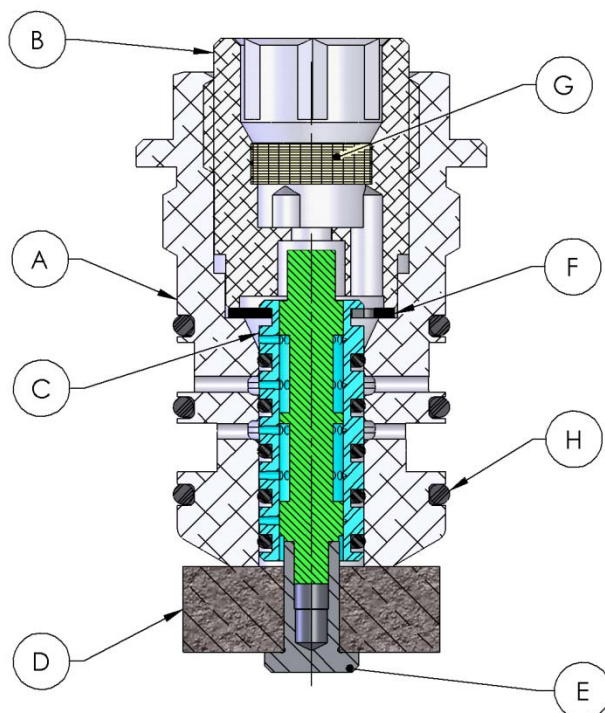

When the valve is removed from the air motor protect the magnet from any form of contamination. (Metallic particles are strongly attracted to the magnet)

Maintenance – Section 5.1 - Assembly Procedure

Pump Assembly – Air Motor

Ensure all parts are clean and degreased.

1. Push bearings (10) into end plates (24) and insert 'O' rings (4) into the large grooves, applying a light coating of grease type #.
2. Apply light coating of grease type # to the seal groove of the piston and insert the 'O' ring portion of the piston seal (8), apply a little more grease to the top of the 'O' ring. Carefully fit the seal strip into the piston groove (fit one half of the seal into the groove and then apply pressure to the o-ring seal already in the groove, and pull the remaining seal into the groove, being careful to avoid unduly stretching the seal strip).
3. Insert grub screw (16) into one of the piston shafts (25) use Loctite studlock 2701 and tighten to 45Nm. Mount this through the piston (26) and screw on the other shaft (25) again using loctite studlock 2701 and tighten to 80Nm. Clean off any residue of loctite.
4. Lightly apply grease type # to the inside of the air motor cylinder (23), insert the piston and shaft sub-assembly into the cylinder at a 45° angle and turn the piston until it is inline with the cylinder.
5. Insert the cylinder end plate sub-assemblies over lightly greased # shafts and into the cylinder. Press parts lightly together, making sure that the Main Valve (3) mounting surfaces are inline.
6. Insert 6 off short tie rods (27) and 2 off long tie rods (28) through the end plates. Fit 16 off washers (12) over the ends of the tie rods. Apply loctite 243 to the LH end of the tie rods and add grease type # to the other end. Fit domed nuts (15) onto the LH loctited end and screw on as far as possible, screw on the remaining domed nuts and tighten in 'cross over' sequence together to 22Nm.
7. Apply grease type # onto the shafts and gently push over the shaft seal (9), lips pointing inwards (Use Tool 502608), push the seal fully home into the end plate. Then fit the bellows retainer (29) over the shafts, smaller hole facing inwards.
8. Screw 502382 assembly spigot onto the piston shaft (25). Using tool 502377 push the bellows (21) over the assembly spigot until the bellows internal spigot locates into the shaft groove. (Using the tool prevents damage to the convolutions)
9. Smear a film of loctite 572 over the nose of the bellows then thread the nut (20) onto the bellows using tool 502377 to push against the nut ensuring the thread starts squarely. Grip the bellows and turn the nut with a 1" A/F spanner until positive resistance is felt. The distance between the nut and the first convolution should be 0 to 1mm.
10. Remove 502382 assembly spigot.
11. Fit mounting brackets (30) to the end plates using 4 off M10 cap head screws (17) and washers (13) tighten to 40Nm. Use loctite 243 on threads.
12. Install vent plugs (32) and elbows (35) to the end plates

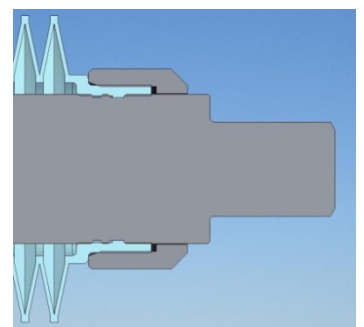
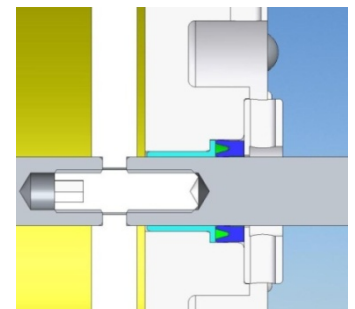

Maintenance – Section 5.1 - Assembly Procedure

Pump Assembly – Air Motor – Control Valves

Pilot Valves (31) - Lightly grease threads and o-rings (grease type #) fit the two pilot valve assemblies into the end plates. Tighten to 8Nm (do not over tighten)

Main Valve (3):-

1. Ensure all parts are free from contamination especially the magnets (43)
2. Lightly grease valve bore of housing (40) and o-ring of spool assembly (41) Use grease type #
3. Carefully insert the spool assembly into the housing until centrally positioned.
4. Insert bumpers (42) into each end of the spool housing.
5. Insert magnets (43) into end cap (44) then fit o-ring (48) lubricate with grease type # and assemble into housing
6. Fit seals (47) into housing
7. Position diaphragm (46) into cage (45) and fit into housing (locate cages with relevant pin positions, ensure diaphragm is centrally located)
8. Secure with screws (49)
9. Ensure threaded plugs (50) and (51) are in position

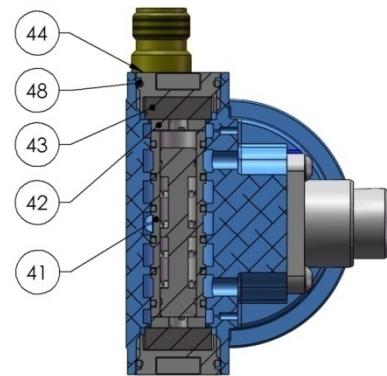

SPOOL DETAIL

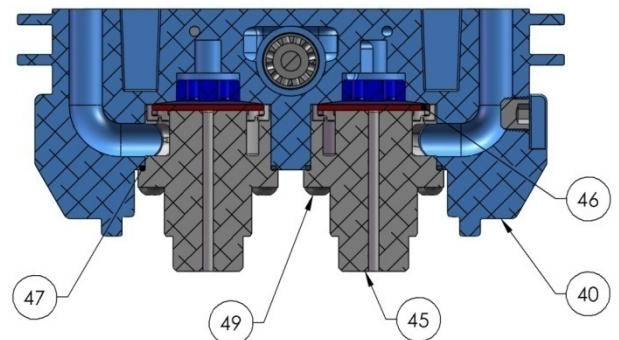

QUICK EXHAUST DETAIL

Assembly Main Valve to Air Motor

1. Fit 2 off o-rings (5) and 4 off o-rings (6) into air motor end plates (24)
2. Secure main valve assembly (3) onto the end plates with 4 off cap head screws (11)
3. Fit sealing o-rings (7) onto the exhaust cage (45) lightly grease #
4. Fit exhaust adapter (33) using screws (14) and washers (18)(19) onto the main valve.

Maintenance – Section 5.2 - Assembly Procedure

Pump Assembly – Fluid Section - Ball Checks

1. **Assemble the Piston:** Insert spring (60) and spring keep (71) into piston (77).
 2. Place the ball (70) against spring keep (71).
 3. Fit the 'O' ring (63) and inlet seat (71) into piston (77).
 4. Fit 'O' rings (61) & (62) to piston keep plate (78) and assemble to piston (77) use Loctite 222 on the threads. Tighten to 50Nm.
-
1. **Assemble the outlet ball check:** Fit outlet seat (73) and O-ring seal (64) into outlet cylinder (76).
 2. Assemble the outlet check (80) into the outlet cylinder (76). Use Loctite 222 on the threads. Tighten to 60Nm.

Maintenance – Section 5.3 - Assembly Procedure

Pump Assembly – Fluid Section / Air Motor

1. Mount inlet cylinders (79) onto end plates and over each shaft and bellows. Secure loosely with lightly greased 4off M12x35 cap head screws (69) and 4off Ø12 washers (65). **Do not tighten at this stage as this may lead to bellows damage when assembling the piston to the shaft.**
2. Apply loctite 243 to the piston shaft threads and screw the piston assemblies onto shafts, tighten up to 40 Nm. Note: If both fluid sections are being assembled tighten by holding one piston with its 10mm hexagon socket and torque the other piston using its socket.
3. Lightly grease with type # the pistons and fit the piston seals (74) & (75), wear lip pointing away from the shaft thread.
4. Fit outlet cylinder sub-assembly over the seal, secure with lightly greased 4off M10x40 cap head screws (67) and tighten evenly all the cap head screws to 50Nm.
5. Mount inlet (93) and outlet (94) manifold to the fluid sections using clamps (92) and seals (91) to orientation required.
6. Install mufflers (90) into exhaust adapter. Alternatively hose fitting (192802) and 1” plug (192803) can be fitted where piped exhaust is required.

Grease Type #	AGMD-010 - Kluber Isoflex Topas 52
----------------------	---

Maintenance – Section 5.4 - Disassembly Procedure

Removal of a single fluid piston

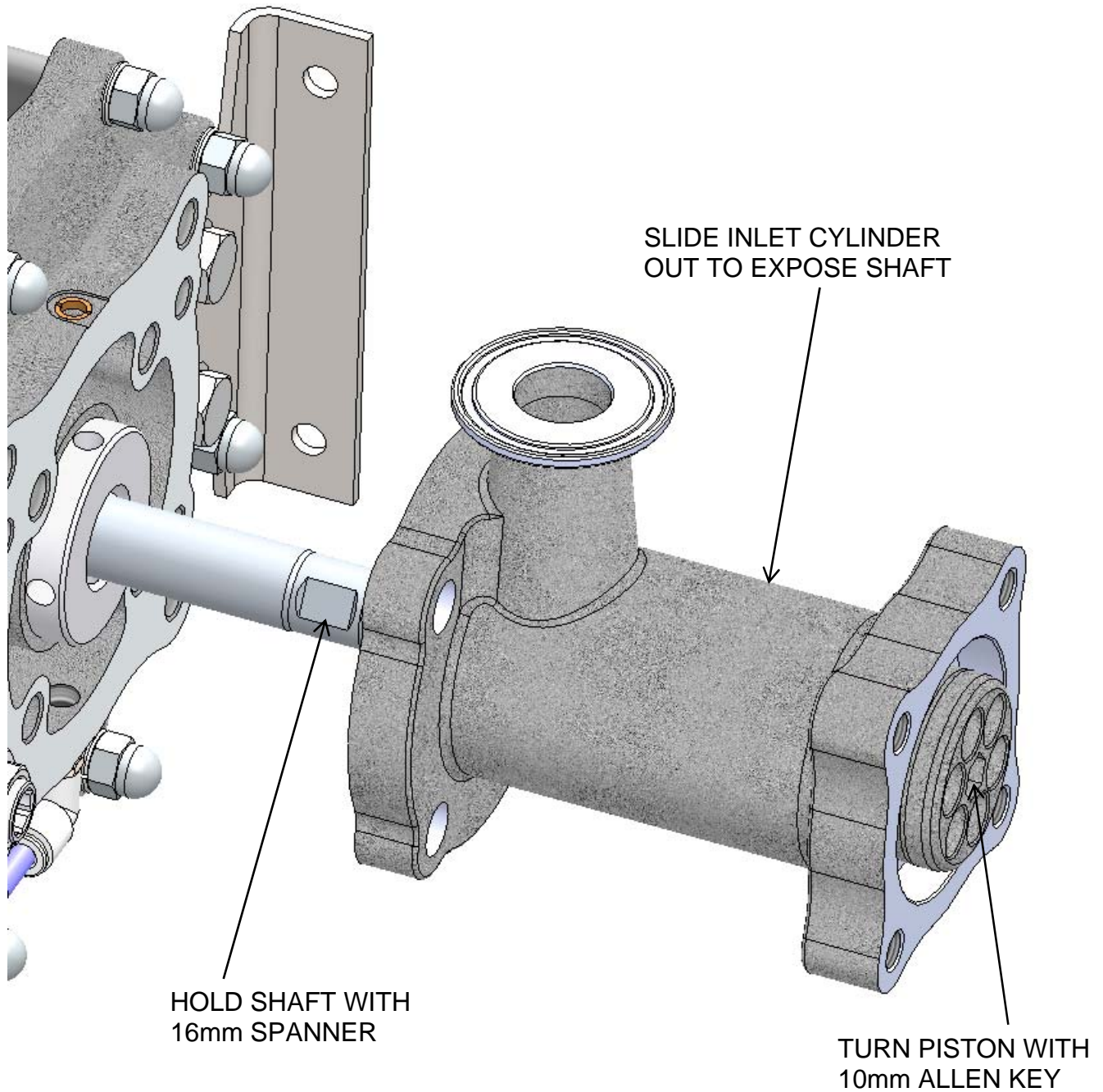

Maintenance – Section 6.1 – General

The working life and thus the expected life prior to replacement of parts within a Paint Pump are greatly affected by three main factors: -

- Abrasiveness of Fluid Pumped
- Pump Duty Cycle
- Fluid Pressure Output requirement

Maintenance Schedule	
Inspection	Operation
Daily	Check for any general fluid or air leakage.
Weekly	Inspect Pump for Correct operation Check for any excessive mechanical noise Check for excessive fluid pressure pulsation
6 Monthly Test	Perform a pump stall test to ensure correct operation. <ul style="list-style-type: none"> • If pump does not stall check fluid piston seals and ball checks, replace as required. • If air is escaping through exhaust check air motor piston seal and quick exhaust diaphragm, replace as required.
12 to 36 Months (Typically 10 million Pump Cycles dependant on air quality and abrasiveness of the paint used)	Replace Air Piston seal Replace shaft seals & bearings
	Inspect and replace if required:- Pilot Air Valves Main Air Valve Parts
	Replace Fluid Piston Seal Replace Balls and Seats Replace Bellows

Maintenance – Section 6.2 – Fault Finding

Symptom	Possible Cause	Remedy
Pump will not 'Prime'	<ul style="list-style-type: none"> a. Air getting into the suction hose/manifold b. Worn piston seals c. Ball checks not seating correctly 	<ul style="list-style-type: none"> a. Check seals and hose connections b. Replace piston seals c. Inspect, clean/replace balls/seats
Pump will not run	<ul style="list-style-type: none"> a. No Air or Fluid supply b. Air piston seal worn. c. Pilot valve assemblies inoperable. d. Main air valve inoperable e. QE diaphragm defective f. Ball checks not seating 	<ul style="list-style-type: none"> a. Check air and fluid supply ball valves and supply hoses. b. Replace Piston seal c. Switch/interchange pilot valves to isolate faulty pilot valve and clean/replace. d. Check clean/replace Air valve. e. Check for constant exhaust air when pump is not running. Check/replace QE diaphragms f. Inspect, clean and/or replace balls and seats.
Pump runs but has excessive pulsation	<ul style="list-style-type: none"> a. Air getting into fluid line, air supply restricted. b. Obstructed fluid ball checks. c. Worn air motor piston seals. d. Worn/failed air motor shaft seals. e. Worn fluid piston seal. f. Air exhaust restricted. 	<ul style="list-style-type: none"> a. Check seals and hose connections. Check air supply b. Remove, clean, and inspect seat, ball, and ball cage. Replace if suspect or worn. c. Replace air motor piston seal. d. Disassemble pump as required to replace air motor shaft seals. e. Replace fluid piston seal. f. Check QE diaphragms and exhaust outlets.
Paint leaking into detection hose (34) Air bleeding from vent plug (32)	<ul style="list-style-type: none"> a. Bellows seal failure b. Air motor shaft seal leaking. (Air leak from vent plug 32). 	<ul style="list-style-type: none"> a. Replace bellows seal (21) b. Check air motor shaft seal (9), replace as necessary

Spare Parts List - Section 7.1

Recommended Spares & Spares Kits for Maple 7/15 Pump			
Kit No.	Part No.	Description	Remarks
❶	250653	Fluid Section Seal & 'O' Ring Kit	
❷	250655	Fluid Section Overhaul Kit	
❸	250657	Air Motor Seal Kit	
#	192765	Pilot Valve Assembly	2off per Pump
#	0115-010015	Main Spool & Sleeve Valve Assembly	1off per Pump
#	193195	Piston Seal	2off per Pump
Check Main Parts List for details of individual Kit Contents			

Accessories - Section 7.2

Accessories / Maintenance		
Part No.	Description	Remarks
192206	1" Sanitary Gasket	
192009	1 & 1/2" Sanitary Clamp	
502608	Seal Insertion Tool	For Shaft seal (9)
502377	Bellows Assembly Tool	
502382	Bellows Assembly Spigot	
AGMD-010	Kluber Isoflex Topas NB 52 (Grease type #)	50 ml Tube
192779	Exhaust Tube Adapter (1" NB hose)	For piped exhaust
192820	Exhaust Tube Adapter (1 1/4" NB hose)	For piped exhaust
192803	1" Manifold Plug	For piped exhaust
192821	1" BSP Heavy Duty Mufflers	Recommended for high pump pressures and cycle rates

